

Neutrix



Instruction manual

Content

1. Manufacturers recommended use
- 1.1 Safety
2. Drawings- & parts description
3. Application
4. Technical data & content of standard package
5. Before use
- 5.1 How to select grinding position
- 5.2 How to select electrode diameter
- 5.3 How to select grinding angle
6. How to use the Neutrix
- 6.1 How to operate the Neutrix
- 6.2 How to grind the electrode
7. Maintenance
- 7.1 Replacing the filter.
- 7.2 Replacing the diamond wheel
8. Parts diagram and list
9. Declaration of conformity
10. Declaration of warranty

1. Manufacturers recommended use

Neutrix has been designed for the sole purpose of grinding tungsten electrodes. Any use, which is not described in this manual, is strictly prohibited.

It is very important that the user reads and understands the content of this instruction manual.

1.1 Safety:

- Check that the machine is undamaged.
- Do not use the machine without the filter.
- Change the filter in accordance with the instruction manual.
- Only turn the machine on when the electrode holder is in the grinding chamber.
- Do not remove the electrode holder before the motor has come to a complete stop.
- Repairs and maintenance must only be carried out by authorised personnel.
- Do not use the machine in humid places.
- Only use original replacement parts.
- Unplug the machine from the mains supply before any maintenance work is undertaken.

2. Drawing & parts description

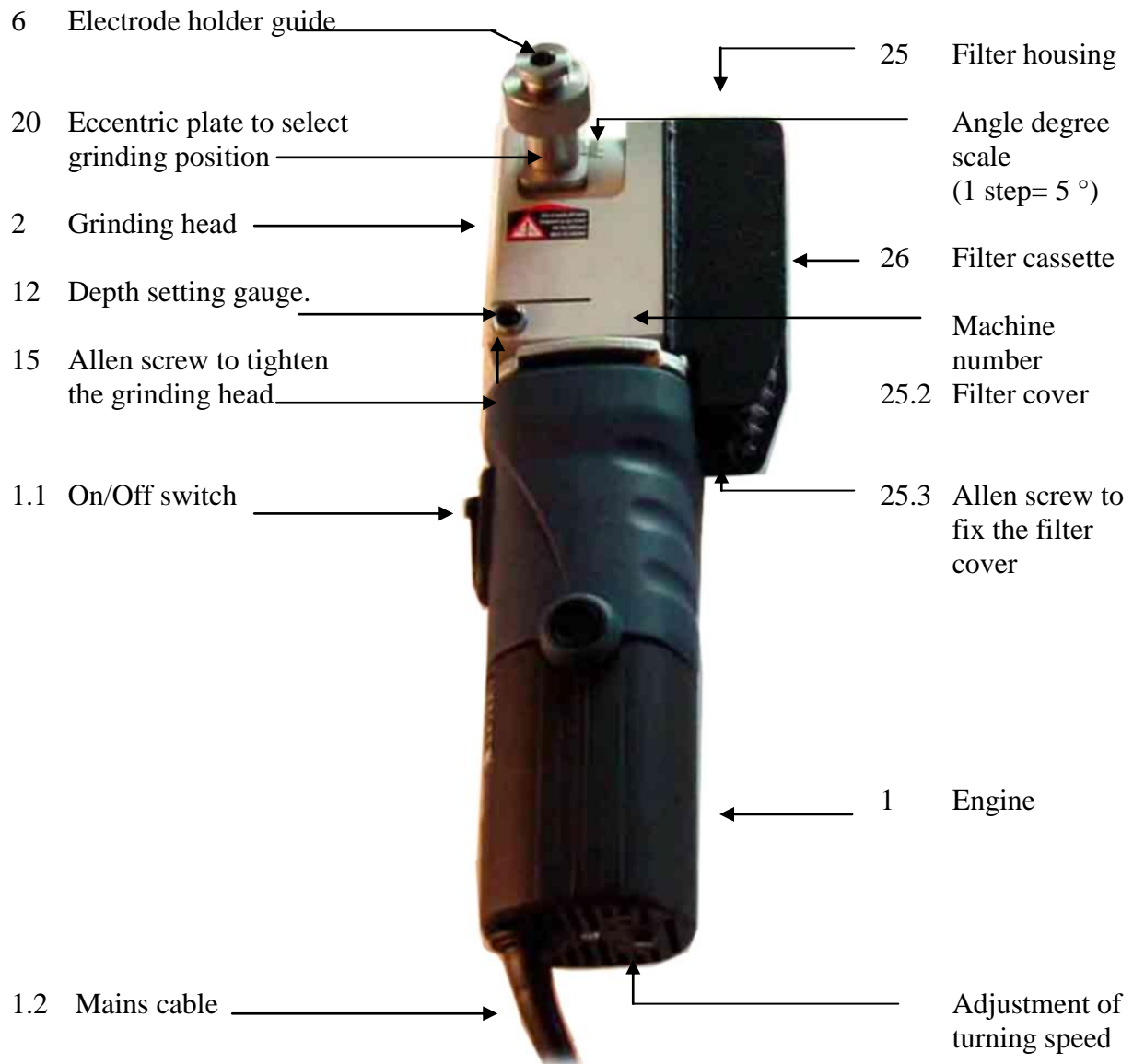

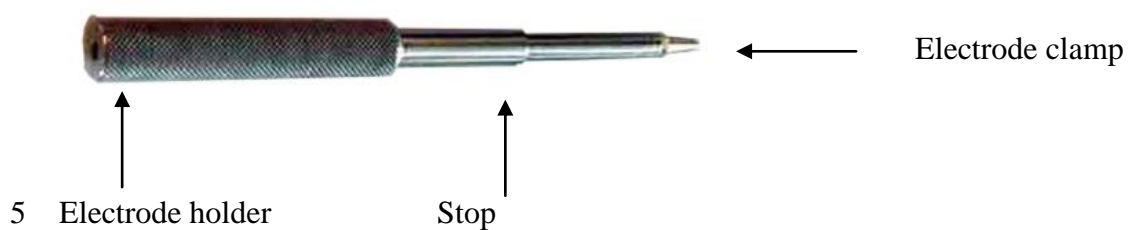
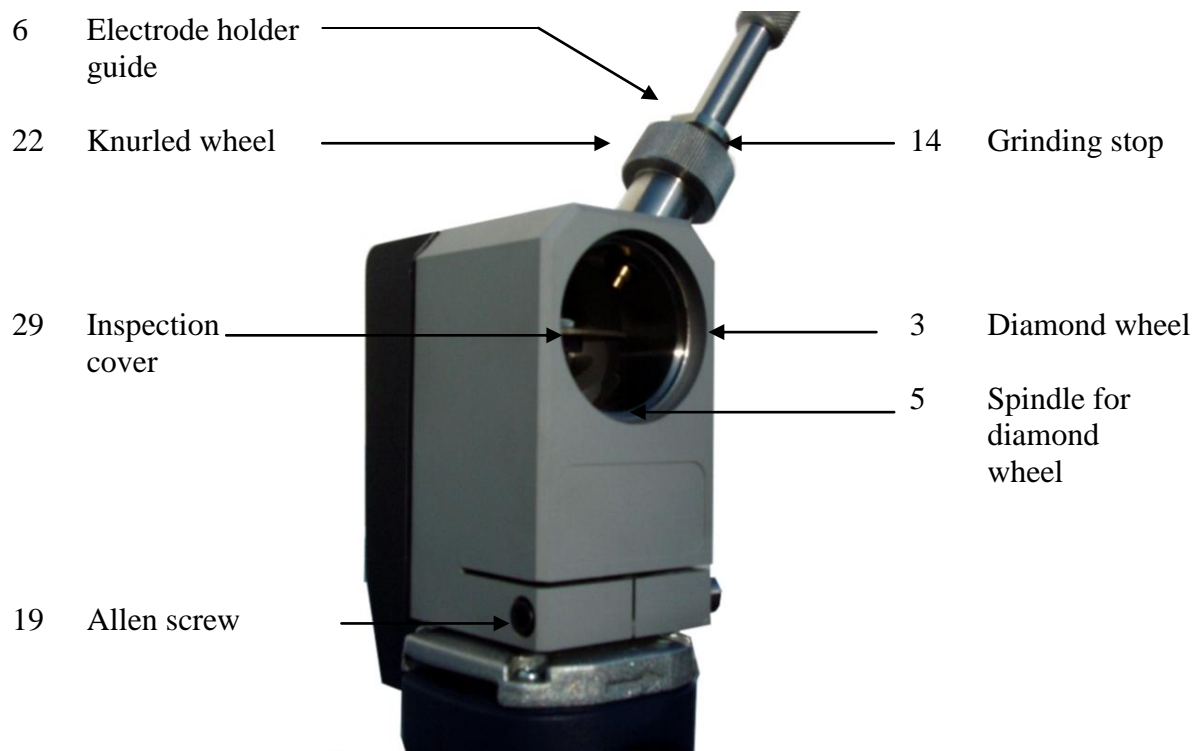

Part No.'s for electrode clamps

16.1	for	1.0 mm
16.2	for	1.6 mm
16.3	for	2.0 mm
16.4	for	2.4 mm
16.5	for	3.2 mm
16.6	for	4.0 mm

3. Application

Neutrix is manufactured to offer the following options:

- Grinding of oxidated or pure tungsten electrodes.
- Grinding electrodes with diameters from 1,0 – 4,0 mm.
- Variable angle adjustment from 15° to 180°.
- If it is necessary to grind electrodes shorter than 15mm a special electrode clamp can be supplied.
- Integrated filter to remove the grinding dust.
- To be able to grind tungsten electrodes on site.
- To achieve an exact and longitudinal ground tip.

4. Technical data & contents of standard package

Motor:	850 Watt
Power:	230V, 50 Hz. Insulation according to EEC 50144
Rpm:	Adjustable between 7000 and 32000
Weight:	2.5 kg
Filter:	Inhalation filter
Diamond wheel:	Ø 40 mm

- **NEUTRIX**

- | | |
|-------------|--|
| Containing: | - Motor Type 850E |
| | - Grinding head with filter housing and filter |
| | - Diamond wheel Ø 40 mm |
| | - Electrode holder |
| | - Electrode clamps 1.6, 2.4, 3.2 mm |

- **Tools**

- Allen key 8 mm
- Allen key 4 mm
- Spanner 13/17 mm
- Spanner 13/14 mm

- **Plastic bag to remove the filter**

5. Before use

Note: Ensure that the grinding head (2) is centred and tightly fixed with the allen screw (15) to the engine.

5.1 How to select grinding position

With the Neutrix it is possible to select 3 different grinding positions

- Unscrew the knurled wheel (22)
- Lift the eccentric plate (20) and turn through 90° to the next position, place the eccentric plate back in the slide of the angle adjustment.
- Tighten the knurled wheel (22)

Eccentric plate to select the grinding position

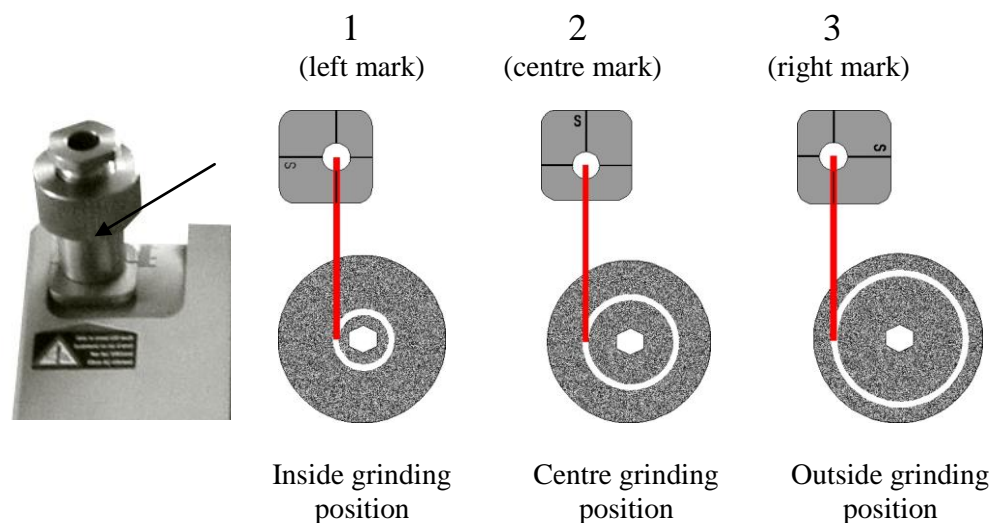

5.2 How to select electrode diameter

There are 3 different electrode clamps (1.6, 2.4, 3.2 mm) supplied with the machine. Unscrew the electrode clamp from the electrode holder and replace with the required size. When delivered the electrode holder is equipped with a 2.4 mm electrode clamp.

5.3 How to select grinding angle

- Loosen slightly the knurled wheel (22).
- Place the degree sign of the guide (20) at the selected angle.
- Tighten the knurled screw (22).

Note: 15° is the smallest included angle of the electrode that can be ground.
180° position makes a flat on the electrode point.
(1 step = 5°)

6. How to use the Neutrix

- Connect the machine to the power supply.
- Adjust the machine speed according to the recommendations on page 8.
- Select the electrode clamp to suit the tungsten to be ground.

6.1 How to operate the Neutrix

- Place the tungsten electrode in the electrode holder (5) with approximately 35 mm protruding.
- Push the electrode clamp into the depth setting gauge (12) until the clamp is located into the allen screw (15), turn clockwise to tighten.
- Put the electrode holder through the electrode holder guide (6) until the tungsten is touching the diamond wheel, this operation can be observed through the inspection cover (29).
- Start the engine (11).

6.2 How to grind the electrode

- Turn the electrode holder, whilst pushing the electrode against the diamond wheel. Do not push too hard in order to avoid blueing of the electrode. This can be viewed through the inspection cover.
- The grinding is completed when the stop of the electrode holder (14) touches the end face of the electrode holder guide (6).
- Switch off the motor and remove the electrode holder when the motor has come to a complete stop.
- Place the electrode holder in the depth setting gauge. Turn anti clockwise and the electrode can be removed.

Recommended turning speed

Diam. of the electrode	1.0 mm	1.6 mm	2.0 mm	2.4 mm	3.2 mm	4.0 mm
Speed adjustment	6	6	5	5	4	4

Note: Do not press too hard at the electrode holder before the stop (14) has been reached.
Remember to put the electrode holder into the grinding chamber before you start the machine and to keep it there until the motor has stopped. (Otherwise grinding dust may come out of the chamber).

7.0 Maintenance

Remove the plug from the power supply before carrying out any maintenance or repairs.

7.1 Replacing the filter

The filter has to be changed when the amount of dust makes it difficult to watch the grinding process through the inspection cover (29).

1. Loosen the allen screw (25.3) at the filter housing (25).
2. Remove the filter cover (25.2).
3. Remove the filter cassette (26) and put it into the plastic bag for disposal.
4. Insert a new filter cassette so that the rubber seal is fitting tight to the grinding head (2).
5. Mount the filter cover and tighten the screw.

7.2 Replacing the diamond wheel

1. Remove the electrode holder (5).
2. Loosen the knurled screw (22)
3. Unscrew the electrode holder guide (14) using the spanner (SW 17)
4. Remove the grinding chamber (10) including the inspection cover (29).
5. Unscrew the nut retaining the diamond wheel, using the spanners (SW14 & SW13), two flats are located on the motor spindle behind the diamond wheel for this purpose.
6. Remove the diamond wheel.
7. Insert a new diamond wheel and replace the retaining nut.
8. Replace the grinding chamber and inspection cover
Replace the electrode holder guide
9. If the grinding head chamber is too dirty it can be cleaned with an alkalisied solution and rinsed with water. **If doing so, remember to remove the filter first.**

8. Parts diagram

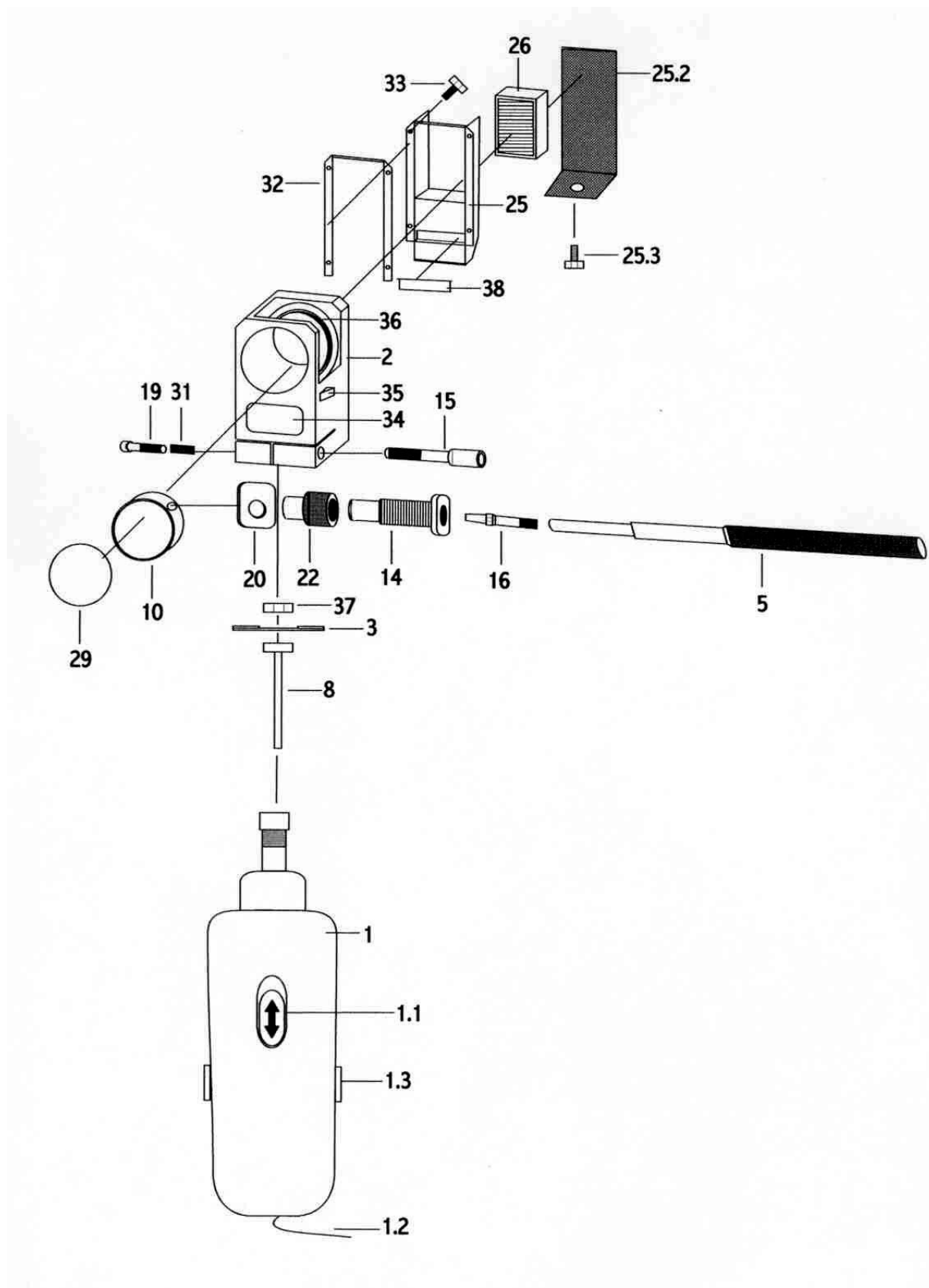

Parts list

Pos.	Description		Part No.
0	Neutrix	1 piece	88896022
1	Motor	1 piece	44510010
1.1	On/Off switch	1 piece	44510011
1.2	Power cable	1 piece	44510012
1.3	Brush for motor	2 pieces	44510013
2	Grinding head	1 piece	44510020
3	Diamond wheel Ø 40 mm	1 piece	44510030
5	Electrode holder	1 piece	44510050
8	Spindle for diamond wheel (SW 13)	1 piece	44510080
10	Grinding chamber	1 piece	44510100
14	Guide for electrode holder (SW 17)	1 piece	44510140
15	Allen key to tighten the grinding head	1 piece	44510150
16	See below		
16.2	Electrode clamp Ø 1,6 mm	1 piece	44510162
16.4	Electrode clamp Ø 2,4 mm	1 piece	44510164
16.5	Electrode clamp Ø 3,2 mm	1 piece	44510165
19	Allen screw (M5 x 30)	1 piece	44510190
20	Eccentric plate to select grinding position	1 piece	44510200
22	Screw	1 piece	44510220
25	Filter housing	1 piece	44510250
25.2	Filter cover	1 piece	44510252
25.3	Allen key to fix the filter cover (M 5 x 6)	1 piece	44510253
26	Filter cassette	1 piece	44510260
29	Inspection cover	1 piece	44510290
31	Spring	1 piece	44510310
32	Rubber seal big	1 piece	44510320
33	Screw to fix filter cassette	4 pieces	44510330
34	Sticker „Neutrix“	1 piece	44510340
35	Safety sticker	1 piece	44510350
36	Degree scale	1 piece	44510360
37	Screw to fix diamond wheel (M 8, SW 13)	1 piece	44510370
38	Rubber seal small	1 piece	44510380

Accessories

39	Case for machine with foam	1 piece	44510390
40	Spanner (SW 13, SW 17)	1 piece	44510400
41	Spanner (SW 13, SW 14)	1 piece	44510410
42	Allen key 8 mm	1 piece	44510420
43	Allen key 4 mm	1 piece	44510430
44	Plastic bag for disposal of filter	1 piece	99140003
16.1	Electrode clamp Ø 1,0	1 piece	44510171
16.3	Electrode clamp Ø 2,0	1 piece	44510172
16.6	Electrode clamp Ø 4,0	1 piece	44510174

9. Declaration of conformity

In accordance with the directive of machinery 98/37/EG, IIA

The machine: Type: NEUTRIX

Machine No. _____

Year: _____

is developed, designed and manufactured according to the above mentioned EEC directive.

Responsible:

Manufacturer: **Inelco A/S**
Handvaerkervej 6

DK-9690 Fjerritslev

Tel.: + 4598211555

Following harmonized norms have been used:

- DIN EN 292 - 1
- DIN EN 292 – 2
- DIN EN 294

Person responsible:

Title: _____

Name: _____

Date: _____

Signature: _____

10. Warranty certificate

	User:	
	Street:	
	Zip, City:	
Company	Country:	

Article – No.:	
Description:	
Machine No.:	
Date of purchase:	

Error:

City, date

Signature:

In case of warranty claims please forwards this certificate to:

**Walter Schnorrer ApS
Anker Engelunds Vej 6
DK-9200 Aalborg SV
Denmark
Fax + 4596342122**