

WS Plus console assembly instructions (8 - 9")

Item number: 1201005

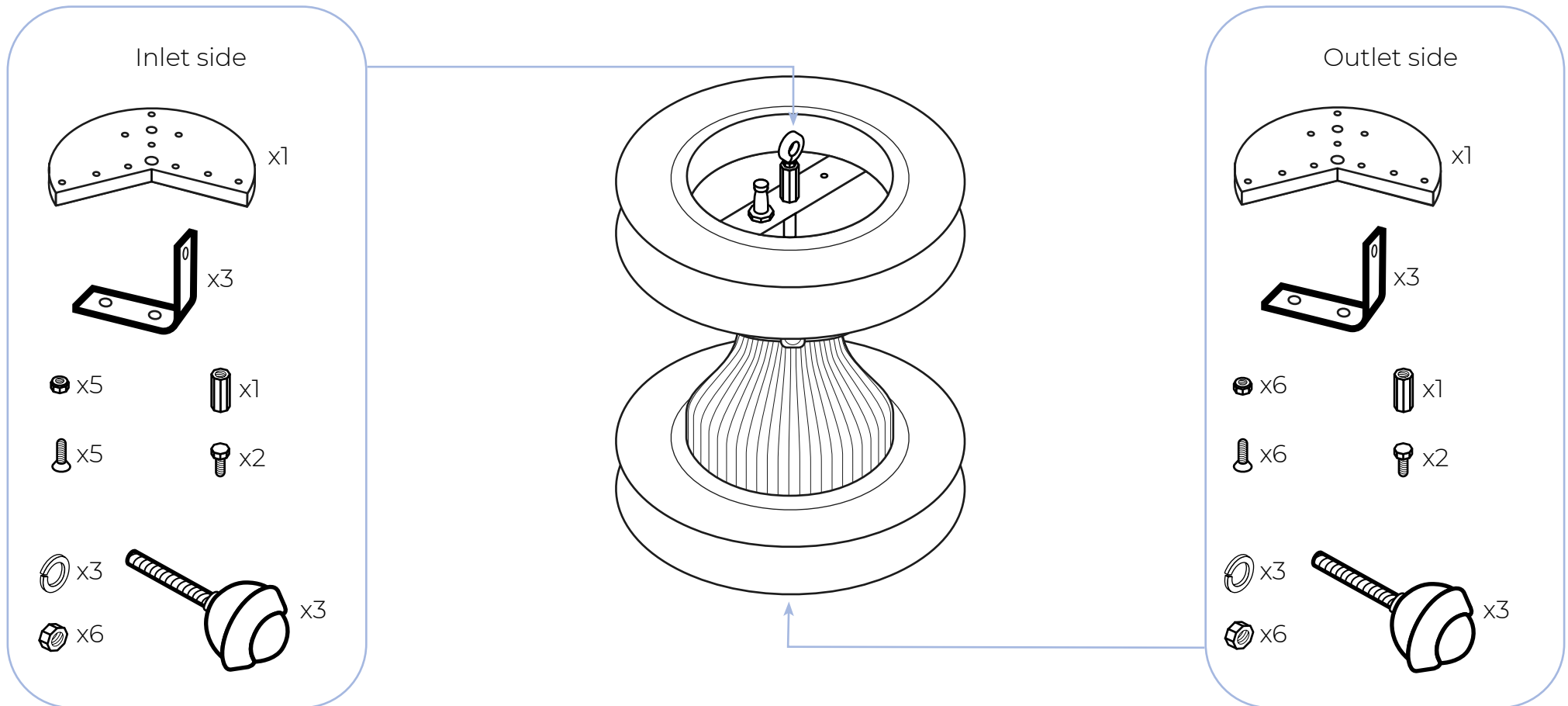

Needed tools: Phillips screwdriver, 8 mm wrench, 10 mm wrench, 6,5 mm drill



Video instruction

1 *(Inlet side)*

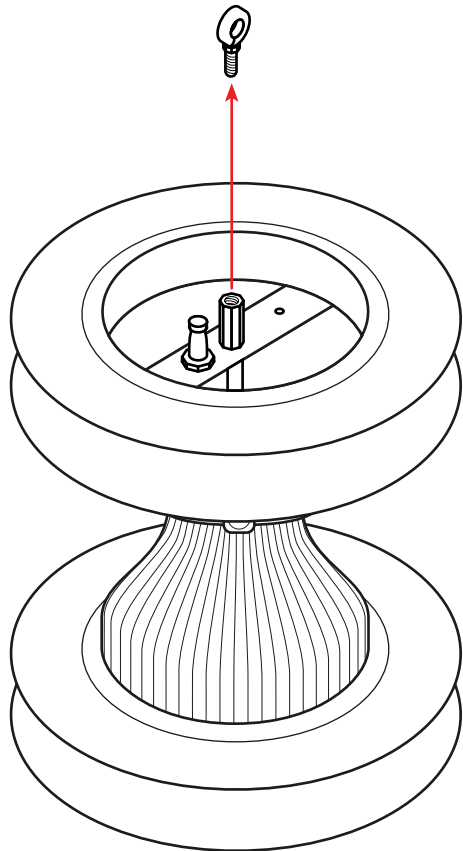

2

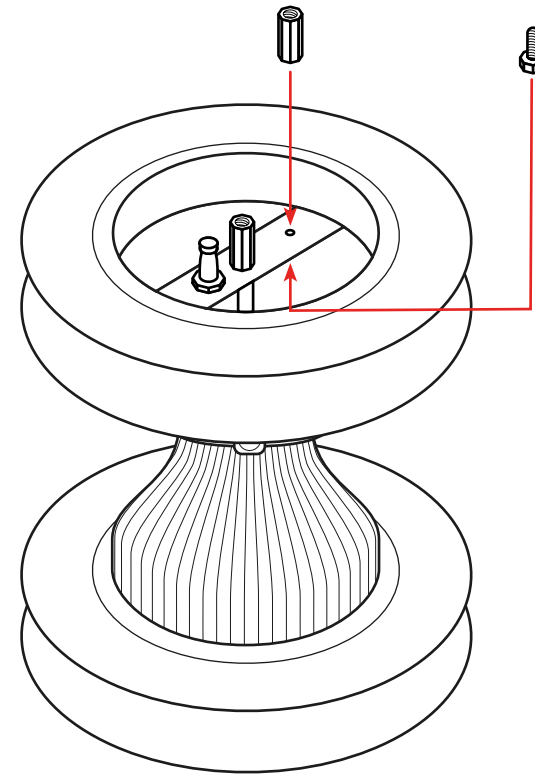

3

⊙ x5

⊙ x5

⊙ x3

⊙ x1

4

⊙ will need to be expanded to 6,5 mm

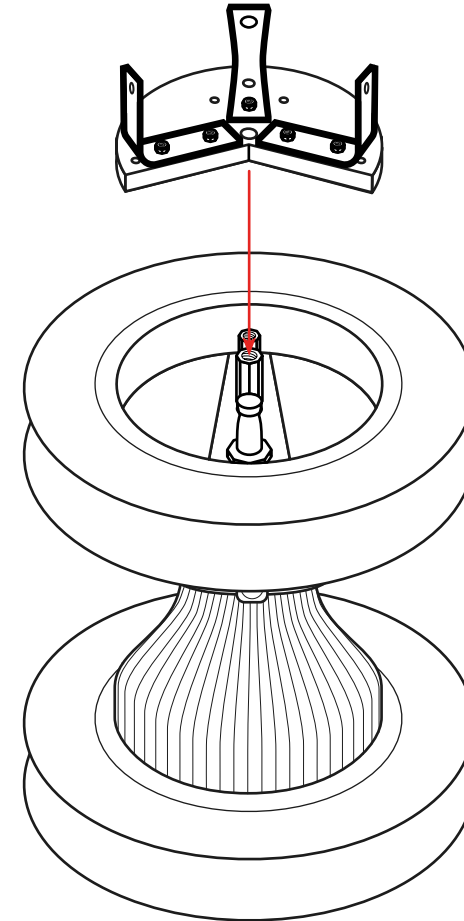
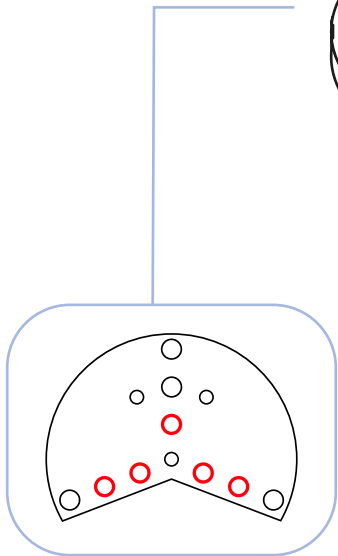
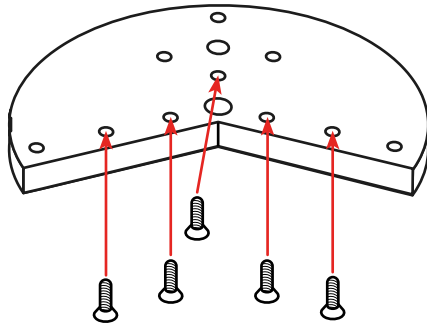
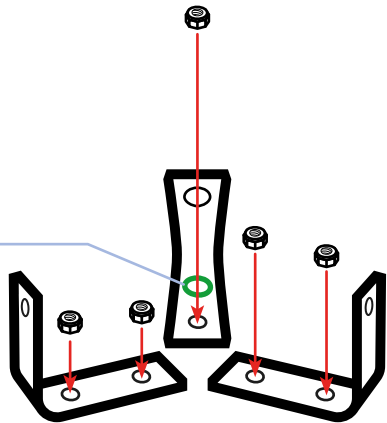

5

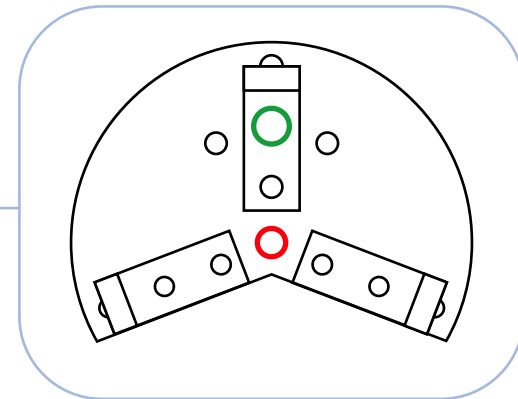
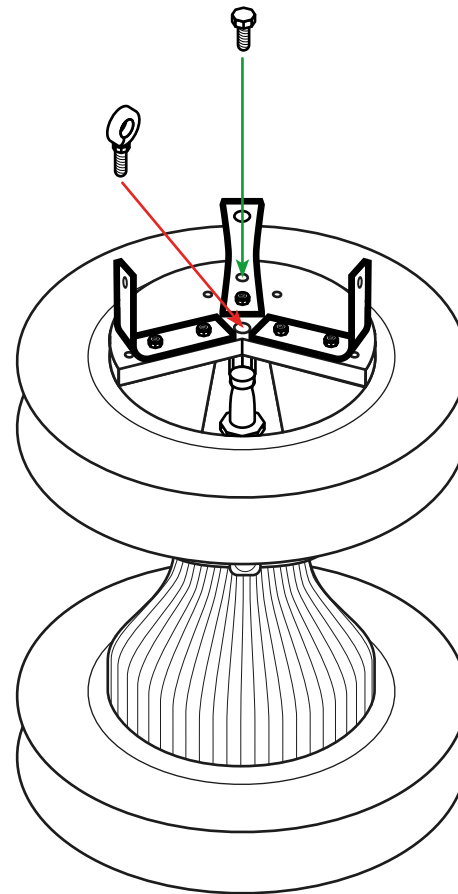

6

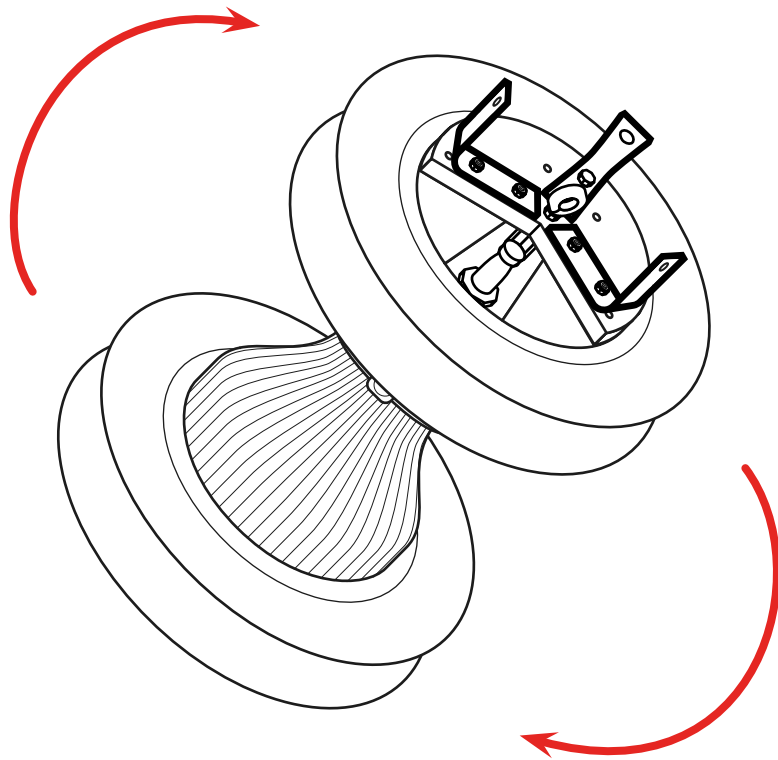

7



(Outlet side)

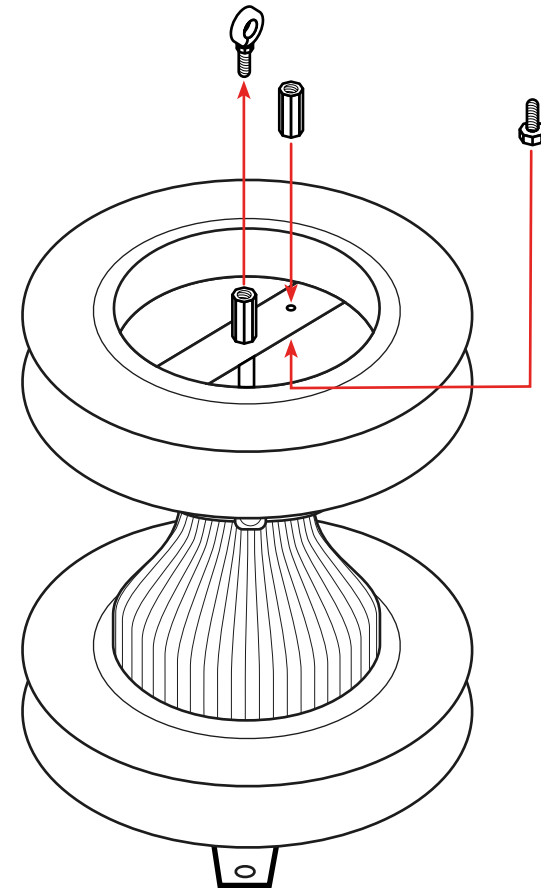

8

⊙ x6

⊙ x6

L x3

⊙ x1

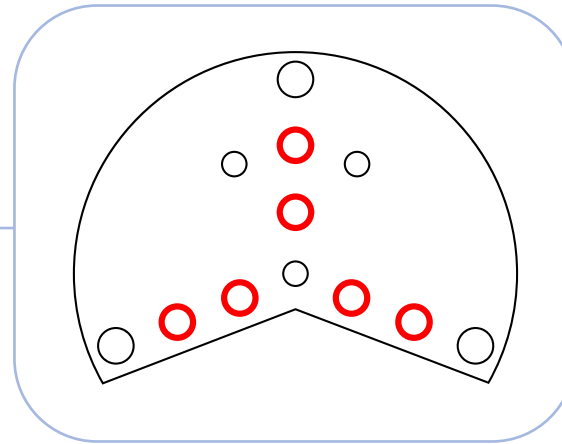
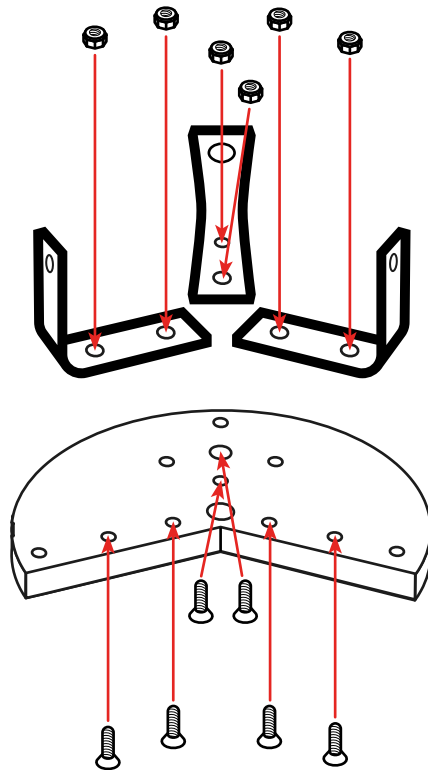

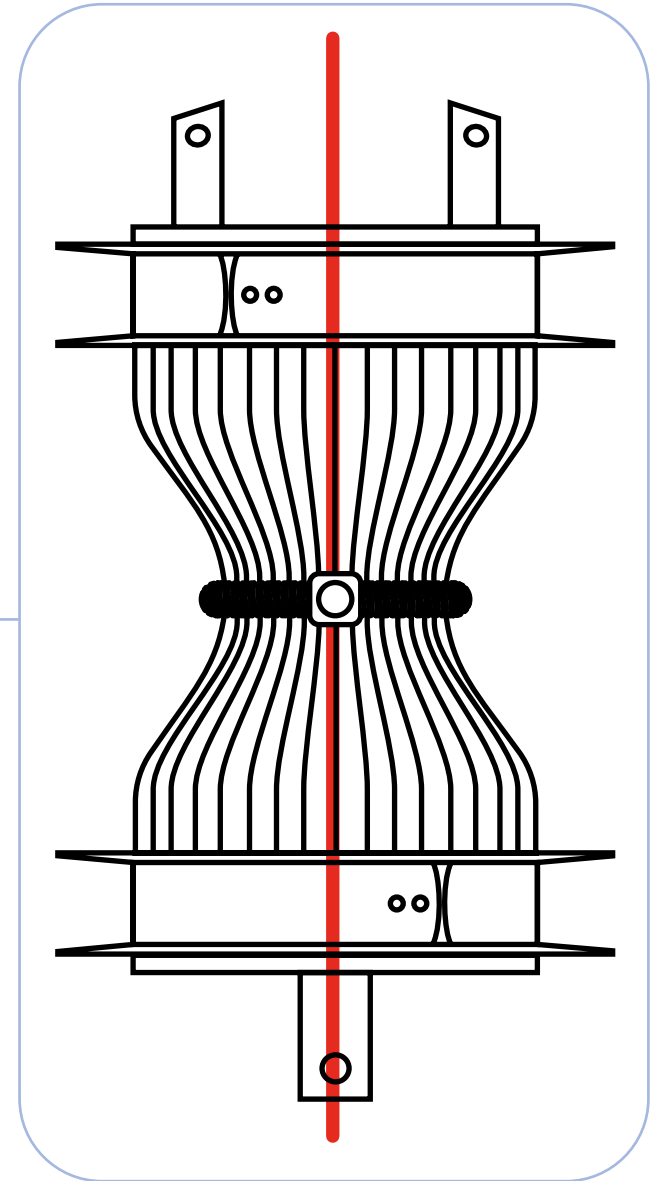
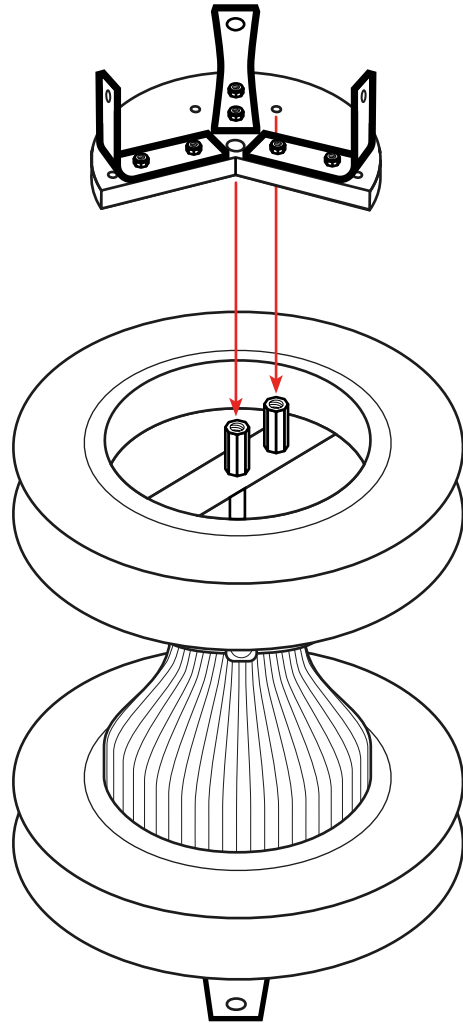

9

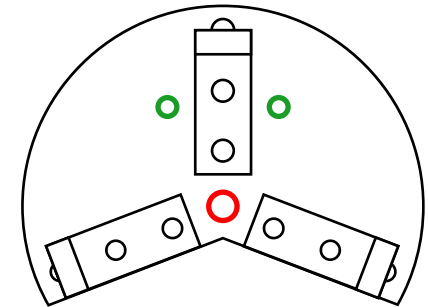
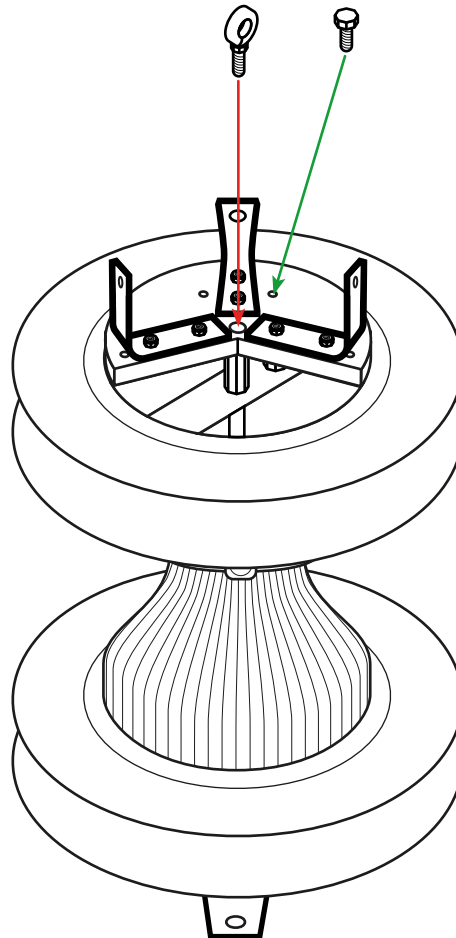

The consoles MUST NOT align

10



Either  works. What is important is that the consoles do NOT align (see step 9)

11

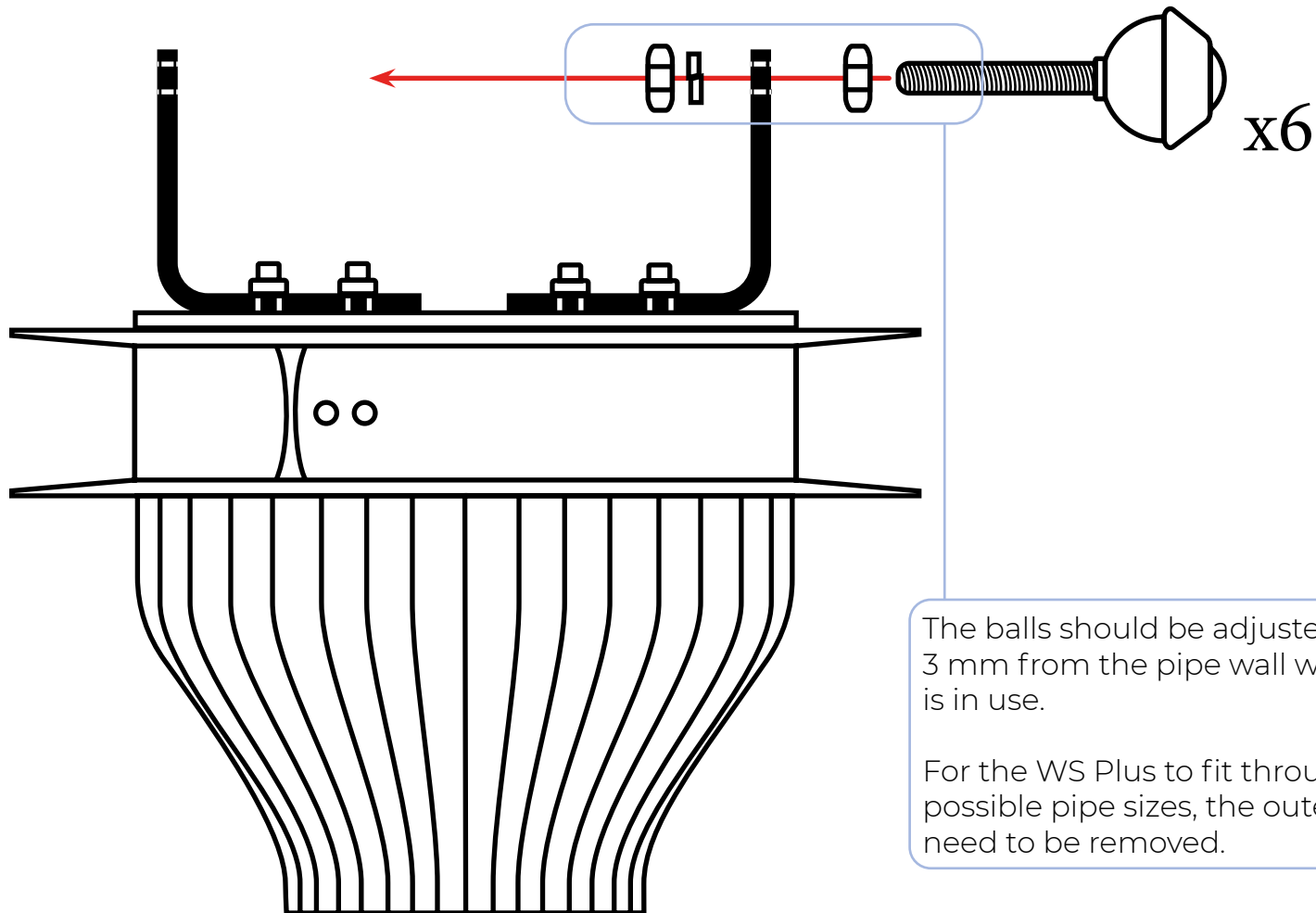

The balls should be adjusted so that they are 3 mm from the pipe wall when the WS Plus is in use.

For the WS Plus to fit through the smallest possible pipe sizes, the outermost nut may need to be removed.

12

